

Bailey

SECTION
P92-8

PRODUCT INSTRUCTIONS

CLASS PA, PB, & PC PNEUMATIC TRANSMITTER USED IN MECHANICAL METERS

INDEX

| | Page |
|----------------------------|------|
| Installation | 2 |
| Operation | 2 |
| Adjustment and Calibration | 2 |
| Maintenance | 3 |
| Replacement Parts | 3 |

The Class PA, PB, and PC Pneumatic Transmitter operates as a position balance system to establish and transmit an output pressure proportional to the mechanical motion of connecting linkage which is positioned in proportion to a change in a measured variable being recorded or indicated in the same instrument case.

CROSS REFERENCES

| <u>Instrument or Equipment</u> | <u>Instruction Section</u> |
|---------------------------------|----------------------------|
| Bailey Recorders and Indicators | M11 1 |
| Reset Booster Relay | P99-7 |
| Connecting Tubing | G18 2 |

BAILEY METER COMPANY • WICKLIFFE, OHIO 44092

INSTALLATION

Mounting

1. The Class P□ Transmitter is normally furnished as a component part of a recording or indicating instrument and is mounted inside the instrument case. If the Class P□ Transmitter is being added to the Recorder or Indicator case, mount Transmitter in desired case position using three 10-32 round head screws.

Supply and Output Connections

2. Make supply and output tubing connections from pressure source to Transmitter at rear of Recorder or Indicator case. Refer to applicable Installation Drawing in Instruction Section M11.1 (Two 1/8 inch 14 NPT tapped holes are provided at rear of case. The upper hole is the output connection, the lower is for supply air.) For general tubing recommendations, refer to Instruction Section G18.2.

3. Supply pressures required for standard output pressure ranges are listed below. If the output range is special, the supply pressure should be 3 psi greater than the maximum output range value.

4. The Class P□ Transmitter is factory calibrated and should require no further adjustment. However, before placing in service, check calibration as outlined under "Adjustment and Calibration" below.

| PNEUMATIC TRANSMITTER | OUTPUT PRESSURE | SUPPLY AIR |
|-----------------------|-----------------|------------|
| Class PA | 3-27 psig | 30 psig |
| Class PB | 3-15 psig | 18 psig |
| Class PC | 5-25 psig | 28 psig |

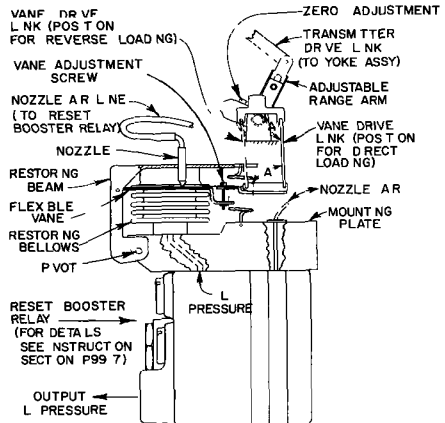

FIGURE 1 - Schematic of Class P□ Transmitter

OPERATION

The Class P□ Transmitter is shown schematically in Figure 1. The Transmitter drive link is positioned by connecting linkage in proportion to changes in the measured variable. This motion is transmitted thru the vane drive link which repositions the flexible vane in relation to the nozzle to produce a proportional change in output pressure transmitted by the Reset Booster Relay.

This change in pressure is applied to the restoring bellows and attached restoring beam nozzle. Expansion and contraction of the bellows moves the restoring beam to reposition the nozzle, thus restoring the original vane nozzle relationship. For operation of the Reset Booster Relay, see Instruction Section P99.7.

ADJUSTMENT AND CALIBRATION

1. Check calibration of measuring mechanism or other component actuating the Class P□ Transmitter as outlined in applicable Instruction Section.

2. Connect a test gage in Transmitter output pressure line. Apply supply pressure to Transmitter connection (see table above).

Check entire installation for leakage with a soapsuds solution.

3. Adjust controlled input to actuating unit so pen or pointer reads 50% chart or scale. Test gage should read midrange output pressure (9 psig for 3-15 range and 15 psig for 3-27 and 5-25 range). If reading is incorrect,

turn zero adjustment screw to obtain correct reading.

4. Adjust input to actuating unit so pen or pointer reads zero chart or scale. Test gage should read minimum output pressure (3 psig for 3-27 and 3-15 range or 5 psig for 5-25 range, or, for reverse loading, 27 psig, 15 psig, or 25 psig, respectively). If not, loosen screw on adjustable range arm and lengthen or shorten adjustable range arm slightly until correct reading is obtained. Tighten screw. Then repeat steps 3 and 4.

5. Adjust input to actuating unit so pen or pointer reads 100% chart or scale. Test gage should read maximum output pressure (27 psig

for 3-27 range, 15 psig for 3-15 range, or 25 psig for 5-25 range, or, for reverse loading, 3 psig for 3-27 or 3-15 range or 5 psig for 5-25 range). If reading is incorrect, turn zero adjustment screw to increase or decrease reading to correct value.

6. Adjust input to actuating unit so pen or pointer reads 50% chart or scale. Test gage should read midrange output pressure. If not, turn vane adjustment screw to obtain correct midrange output pressure value.

7. Repeat steps 4 thru 6 until correct output pressures are obtained at midrange, minimum, and maximum output pressure values.

MAINTENANCE

The Class P□ Transmitter requires no routine maintenance. Check Transmitter for broken or damaged parts or for friction in connecting linkage. If Transmitter operates incor-

rectly, check for leakage with a soapsuds solution at all air connections. Check calibration of actuating unit and Reset Booster Relay (see Instruction Section P99 7) and Transmitter

REPLACEMENT PARTS

Spare Parts Kits

The Spare Parts Kits shown in Figure 2 should be carried in stock. Specify the Spare Parts Kit part number to order a complete kit.

Ordering Individual Parts

Figure 2 is a Parts Drawing of the Class P□ Pneumatic Transmitter. Normally this drawing will apply to the Transmitter furnished. However, there may be individual differences in specific Transmitters because of

a design changes made since the printing of this Instruction Section, or

b. special design of Transmitter to make it suitable for a specific application

Therefore, when ordering parts, assure receipt of correct replacements by specifying on the order:

1. the complete nomenclature stamped on instrument nameplate and the Code Label Number (see Figure 2) of the Transmitter for which parts are desired, and

2. the Parts Drawing Number on which each part is illustrated. (The Parts Drawing Number is given in the Figure caption.)

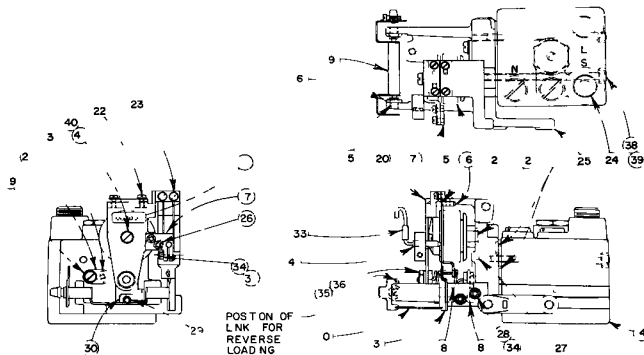

| L S T O F P A R T S | | | | | |
|---------------------|--------------|---------------------------|-----|---------------|-----------------------------------|
| TEM | PART NO | N A M E | TEM | PART NO | N A M E |
| | CODE LABEL | SPECFY NWHEN ORDERNG PTS | 25 | SEE TABLE | SUPPORT BLOCK |
| 2 | 45 2007 | BELLOWS ASSEMBLY | 25 | 4 40 X 1/4" | PAN HD SCREW 2 REQ |
| 3 | 45 953 | VANE ASSEMBLY | 27 | 68 4 | P VDT |
| 4 | 45 949 | NOZZLE ASSEMBLY | 28 | 4 40 X 5/8" | SOC HD SCREW, 2 REQ |
| 5 | 45 850 | JEWELLED BEAR NG, 2 REQ | 29 | 4 40 X 5/8" | SOC HD CAP SCREW |
| 6 | 97 32 4 | PAL NUT, 2 REQ | 30 | 45 2032 | ADJ SCREW BRACKET |
| 7 | 45 956 | CLAMP PLATE | 3 | 4 40 X 1/4" | SOC HD SCREW |
| 8 | 45 2009 | SPR NG SUPPORT | | | |
| 9 | 45 2035 | OFFSET DR VE ARM | 33 | R9023 0 29 | RM CD NO 38 NSL L ON TUB NG 2" LG |
| 0 | 45 2039 | L N K | 34 | NO 4 SAE | SPR NG LOCKWASHER 5 REQ |
| | 53 428 2 | O R NG, 3 REQ | 35 | 208 00 | SHKPRF LOCKWASHER 2 REQ |
| 2 | 53 428 3 | O R NG | 36 | 8 32 | HEX NUT, 2 REQ |
| 3 | 53 428 0 | O R NG | | | |
| 4 | SEE TABLE | BOOSTER RELAY | 38 | 8 32 X 2 1/2" | F L HD SCREW, 2 REQ |
| 5 | 68 820 | BELLOWS BEAM H WSE SPR NG | 39 | NO. 8 SAE | SPR NG LOCKWASHER 2 REQ |
| 6 | 68 824 | TAPPE PAD, 2 REQ | 40 | 6 32 X 1/4" | PAN HD SCREW |
| 7 | SEE TABLE | CLAMP BLOCK | 4 | 206 00 | SHKPRF LOCKWASHER |
| 8 | SEE TABLE | RANGE SPR NG | | | |
| 9 | 6 32 X 3/16" | PAN HD NT SEMS | | | |
| 20 | 45 2040 | BELLOWS BEAM | | | |
| 2 | 45 945 | CONNECTOR ASSEMBLY | | | |
| 22 | 3 48 X 1/4" | PAN HD EXT SEMS 4 REQ | | | |
| 23 | 2 56 X 3/16" | PAN HD NT SEMS 2 REQ | | | |
| 24 | 95 04 | P PE PLUG SEE TABLE | | | |

| USE | RANGE PS | TABLE | | | | | |
|----------------------|----------|-------------------------------|----------------------|---------------------|--------------------|------------------|-------------------|
| | | PNEUMAT C TRANSM TTER PART NO | TEM 25 SUPPORT BLOCK | TEM 4 BOOSTER RELAT | TEM 8 RANGE SPRING | TEM 24 P PE PLUG | TEM 7 CLAMP BLOCK |
| CLASS PA TRANSM TTER | 3 27 | 45 2043 | 45 2005 | 53 9700 3 | 68 870 | OM T | 68 246 |
| CLASS PB TRANSM TTER | 3 5 | 43 2043 3 | 45 2005 | 53 9700 3 | 68 97 | OM T | 68 246 |
| CLASS PC TRANSM TTER | 5 25 | 45 2043 | 45 2005 | 53 9700 3 | 68 870 1 | OM T | 68 246 |

| SPARE PARTS KIT PART NO 256 60 | | SPARE PARTS KIT PART NO 256 60 2 | |
|--------------------------------|--------------|----------------------------------|--------------|
| QTY | TEM NO | QTY | TEM NO |
| CLASS PA & PC TRANSM TTER | | CLASS PB TRANSM TTER | |
| EA | 2 0 2, 3 A 8 | EA | 2 0 2, 3 A 8 |
| 3 EA | | 3 EA | |

FIGURE 2 Parts Drawing P99 23, Class PA, PB, and PC Pneumatic Transmitter